

BLUE CYPRESS REPLAT NO. 2 AT PALM BEACH POLO AND COUNTRY CLUB

BEING A REPLAT OF LOTS 43 THROUGH 48 OF BLUE CYPRESS REPLAT AT PALM BEACH POLO AND COUNTRY CLUB
 ACCORDING TO THE PLAT THEREOF AS RECORDED IN PLAT BOOK 116, PAGES 163 THROUGH 165,
 PUBLIC RECORDS OF PALM BEACH COUNTY, FLORIDA, SECTION 15, TOWNSHIP 44 SOUTH, RANGE 41 EAST.
 VILLAGE OF WELLINGTON, PALM BEACH COUNTY, FLORIDA
 JANUARY, 2019
 SHEET 2 OF 2

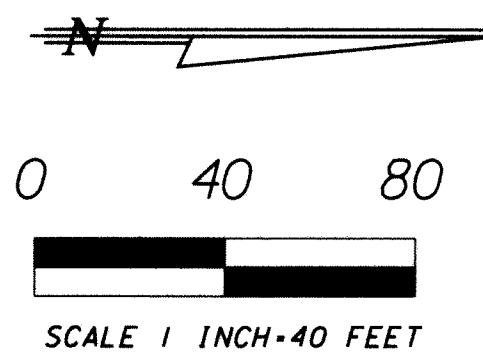

2

STATE OF FLORIDA
 COUNTY OF PALM BEACH
 THIS PLAT WAS FIELD FOR
 RECORD AT _____ P.M.
 THIS _____ DAY OF _____
 A.D. 2019 AND DULY RECORDED
 IN PLAT BOOK _____ ON
 PAGES _____ AND _____

SHARON R BOCK
 CLERK AND COMPTROLLER

BY: _____
 DEPUTY CLERK

LEGEND & ABBREVIATIONS:

- R RADIUS LENGTH
- Δ DELTA ANGLE
- L ARC LENGTH
- ℄ CENTER LINE
- P.B. PLAT BOOK
- P. PAGE
- IR IRON ROD
- N/D NAIL & DISK
- ESMT. EASEMENT
- ORB OFFICIAL RECORD BOOK
- EXIST EXISTING
- FND. FOUND
- IR/C IRON ROD & CAP
- FPL FLORIDA POWER & LIGHT
- B.E. BUFFER EASEMENT
- U.E. UTILITY EASEMENT
- D.E. DRAINAGE EASEMENT
- P.O.B. POINT OF BEGINNING
- P.O.C. POINT OF COMMENCEMENT
- PCP PERMANENT CONTROL POINT
- PRM PERMANENT REFERENCE MONUMENT
- M.E. MAINTENANCE EASEMENT
- D.E. DRAINAGE EASEMENT
- L.A.E. LIMITED ACCESS EASEMENT
- L.M.A.E. LAKE MAINTENANCE ACCESS EASEMENT
- W.E. WATER EASEMENT
- S.E. SANITARY EASEMENT
- SET PRM LB# 6837
- ⊙ FOUND PERMANENT CONTROL POINT #6837
- MONUMENT TO BE SET LB# 6837

SURVEYOR'S NOTES

1. BEARINGS SHOWN HEREON ARE ASSUMED AND ARE BASED ON THE SOUTH LINE OF BLUE CYPRESS REPLAT AT PALM BEACH POLO AND COUNTRY CLUB, AS RECORDED IN PLAT BOOK 116, PAGES 163 THROUGH 165, PUBLIC RECORDS OF PALM BEACH COUNTY, FLORIDA, HAVING A BEARING OF NORTH 89°37'48" WEST AND ALL OTHER BEARINGS SHOWN ARE RELATIVE THERETO.
2. THERE SHALL BE NO BUILDING OR ANY HABITABLE STRUCTURE PLACED ON DRAINAGE EASEMENTS OR UTILITY EASEMENTS.
3. THERE SHALL BE NO TREES OR SHRUBS PLACED ON UTILITY EASEMENTS WHICH ARE PROVIDED FOR WATER AND SEWER USE.
4. LANDSCAPING ON OTHER EASEMENTS SHALL BE ALLOWED ONLY AFTER CONSENT OF ALL UTILITY COMPANIES OCCUPYING SAME.
5. IN THOSE CASES WHERE EASEMENTS OF DIFFERENT TYPES CROSS OR OVERLAP, DRAINAGE EASEMENTS SHALL HAVE FIRST PRIORITY, UTILITY EASEMENTS SHALL HAVE SECOND PRIORITY AND ALL OTHER EASEMENTS SHALL BE SUBORDINATE TO THESE WITH THEIR PRIORITIES BEING DETERMINED BY THE USE OF RIGHTS GRANTED.
6. ALL LINES INTERSECTING CURVES, AS SHOWN HEREON, ARE ASSUMED TO HAVE NON-RADIAL BEARINGS UNLESS OTHERWISE NOTED AS RADIAL BEARING.
7. THIS PLAT, AS RECORDED IN ITS GRAPHIC FORM, IS THE OFFICIAL DEPICTION OF THE LANDS DESCRIBED HEREIN AND WILL IN NO CIRCUMSTANCES BE SUPPLANTED IN AUTHORITY BY ANY OTHER GRAPHIC OR DIGITAL FORM OF THE PLAT. THERE MAY BE ADDITIONAL RESTRICTIONS THAT ARE NOT RECORDED ON THIS PLAT THAT MAY BE FOUND IN THE PUBLIC RECORDS OF PALM BEACH COUNTY, FLORIDA.
8. THIS INSTRUMENT WAS PREPARED BY MICHAEL D. BONIN P.S.M. UNDER THE SUPERVISION OF MICHAEL F. SEXTON P.E., P.S.M., IN AND FOR THE OFFICES OF SEXTON ENGINEERING ASSOCIATES, INC.
9. THE APPROVAL OF A REPLAT BY THE GOVERNING BODY OF A LOCAL GOVERNMENT, WHICH ENCOMPASSES LANDS EMBRACED IN ALL OR PART OF A PRIOR PLAT FILED OF PUBLIC RECORD SHALL, UPON RECORDATION OF THE REPLAT, AUTOMATICALLY VACATE AND ANNUL ALL OF THE PRIOR PLAT ENCOMPASSED BY THE REPLAT.

SURVEYOR'S CERTIFICATION

THIS IS TO CERTIFY THAT THE PLAT SHOWN HEREON IS A TRUE AND CORRECT REPRESENTATION OF A SURVEY MADE UNDER MY RESPONSIBLE DIRECTION AND SUPERVISION; THAT SAID SURVEY IS ACCURATE TO THE BEST OF MY KNOWLEDGE AND BELIEF; THAT PERMANENT REFERENCE MONUMENTS ("P.R.M.'s") HAVE BEEN PLACED AS REQUIRED BY LAW, AND MONUMENTS ACCORDING TO CHAPTER 177, 091(9), FLORIDA STATUTES WILL BE SET UNDER THE GUARANTEES POSTED WITH THE VILLAGE OF WELLINGTON, FLORIDA; AND FURTHER THAT THE PLAT AND SURVEY DATA COMPLIES WITH ALL THE SURVEY REQUIREMENTS OF CHAPTER 177, FLORIDA STATUTES, AS AMENDED, AND THE ORDINANCES OF THE VILLAGE OF WELLINGTON, FLORIDA.

BY: Michael F. Sexton
 MICHAEL F. SEXTON
 LICENSE NO. 3596
 STATE OF FLORIDA

DATE: 01-12-2019

PROFESSIONAL
 SURVEYOR AND MAPPER

